

Genetic Structure of Grass Carp Populations in the Missouri and Mississippi River Basins, USA

BOBBI M. ADAMS¹, KATIE N. BERTRAND, MICHAEL L. BROWN, AND DONALD AUGER

South Dakota State University, Department of Natural Resource Management, SNP 138, Box 2140B,
Brookings, SD 57007, USA (BMA, KNB, MLB)
South Dakota State University, Department of Biology and Microbiology, SNP 251A, Box 2140D,
Brookings, SD 57007, USA (DA)

ABSTRACT We provided an early characterization of the genetic structure of the grass carp (*Ctenopharyngodon idella*) population as it expands its distribution in both the Missouri and Mississippi River basins. Further, we provided initial comparisons of allelic richness at 17 polymorphic microsatellite markers between 56 grass carp from the USA, and six from the Yangtze River in China. The number of alleles per locus ranged from two to eight and size ranges of alleles for fish collected from the invaded and native ranges were similar ($P \leq 0.001$; 107–226 bp) to those previously reported in the literature. Distance-based clustering methods did not suggest significant groupings by river reaches. Using allele frequencies, we identified a possible population bottleneck (heterozygosity excess in the Missouri River upstream sample group) between the uppermost Missouri River reach and all other samples which may indicate a difference in the level of diversity between the locations. Within population allelic diversity (A_S) was 1.56, 2.27, and 1.39 for samples from the Missouri River in South Dakota and Nebraska, samples from the Missouri River in Missouri, and samples from the Mississippi River respectively. Despite isolation from the native population and exposure to a novel environment, in the nearly 50 years since their first introduction from China, the genome at these 17 microsatellite loci has diverged little from fish collected in their native range. We found only weak evidence to suggest that grass carp throughout the Missouri and upper Mississippi River basins are reproductively isolated from one another at this time. Range expansion can result in divergent genetic structure of subpopulations, which may provide clues about the mechanism of invasion success and inform fisheries scientists how to focus management efforts most effectively. These results provided a unique glimpse at a species early in the process of range expansion in the USA and provide a benchmark for future assessments of grass carp genetic structure in the Great Plains.

KEY WORDS Asian carp, genetic structure, grass carp, invasion, population structure

Grass carp (*Ctenopharyngodon idella*) are native to eastern Asia and their native range boundaries are the Amur River of eastern Russia and China and the Xi (“West”) tributary to the Pearl River of southern China (Shireman and Smith 1983). The species was introduced into the United States of America (USA) in 1963 for use as a biocontrol of nuisance aquatic vegetation in extensive aquaculture systems (Stevenson 1965). Initial importations of the species were from Malaysia and Taiwan to aquaculture facilities in Arkansas and Alabama (Courtenay et al. 1984). Some of the Malaysian stock held in Arkansas escaped and became the first grass carp documented entering public water (Courtenay et al. 1984). However, multiple unintentional releases have occurred in Arkansas (Mitchell and Kelly 2006) and free-ranging grass carp were first captured in the White River of Arkansas in 1970 (Bailey 1972). Despite regulatory and physical controls, grass carp continue to colonize aquatic ecosystems in the USA and are now present in at least 45 of the contiguous states (Nico et al. 2011). Although negative ecological effects of grass carp are well-documented (Pipalova 2003, 2006, Hutorowicz and Dziedzic 2008), information describing their basic biology and genetic diversity in North America is limited, particularly in the Great Plains.

To prioritize allocation of resources for the control and management of grass carp, empirical ecological and genetic information is required (Ricciardi and Rasmussen 1998). Population genetic analyses across the invaded range can estimate demographic parameters and support development of management strategies. Two potential outcomes of freshwater fish introductions are geographic isolation from the source population and genetic bottlenecks. Isolated populations may experience an increased rate of inbreeding which can reduce the amount of heterozygosity relative to the founding population, and genetic bottlenecks result from intense selective pressure imposed on founders of a newly introduced population, which may result in limited genetic diversity in the newly invaded population and rates of genetic drift across introduced and source populations that are greater than those in the source population alone. Allelic differences among geographically isolated groups can identify prolific source populations and isolated sink populations, and allow investigation of subpopulation relatedness and invasion pathways. Additionally, inferences based on traditional ecological studies and genetic approaches can be combined to inform predictive demographic models. Our goal was to describe the population structure of grass carp collected in the Missouri

¹ Present Address: Washington State University, School of Biological Sciences, PO Box 644236, Pullman, WA 99164, USA

¹ Corresponding author email address: bobbiadams1@gmail.com

and Mississippi Rivers to improve our understanding of this invasive species and the effectiveness of their management. Our specific objectives were to evaluate the use of microsatellites developed by Li et al. (2007) to describe the genetic structure of fish collected from the Missouri and Mississippi Rivers, using grass carp collected in the Yangtze River, China as a baseline, and to perform preliminary investigation into the genetic structure of a subset of the USA population.

STUDY AREA

We defined three USA river reaches to evaluate population genetic dynamics, including: Missouri River Upstream (MOU; includes samples collected in South Dakota and Nebraska), Missouri River Downstream (MOD; includes samples collected in Missouri), and Mississippi River (MS; includes samples collected in Iowa and Missouri upstream of St. Louis; Table 1). We obtained samples from 12 sites within the Missouri and Mississippi River basins

(Fig. 1). Sample collections from the Missouri River were from Yankton County, South Dakota, Cass County, Nebraska, and the Davis Dale Conservation Area, the Franklin Island Conservation Area, the Hart Creek Conservation Area, the Overton Bottoms Conservation Area, the Eagle Bluffs Conservation Area, and Boone County, Missouri. Within the Mississippi River Basin, we collected fish in Iowa from the Port Louisa National Wildlife Refuge and Dead Slough, the Ted Shanks Conservation Area, Missouri, and Gilead Slough, Illinois (Fig. 1).

We included DNA from six fish collected in the Yangtze River, China (provided by J. Tong; Institute of Hydrobiology, Chinese Academy of Sciences, Wuhan, China). These fish represented some of the allelic diversity present in the native range, generating a baseline from which we could compare fish collected in the Missouri and Mississippi Rivers and provided a positive control for marker success.

Table 1. Location, sample size (n), and biological characteristics of grass carp (*Ctenopharyngodon idella*) collected from each of 12 sample sites throughout the Mississippi and Missouri River basins, USA, 2008–2009.

Group ^a	State	n	Sample site	Latitude (N)	Longitude (W)	Total length range (mm)	Weight range (kg)
MOU	SD	16	Yankton County	42.7491	–96.9537	560–891	1.93–5.39
	NE	2	Cass County	40.9704	–95.8477	750–960	5.00–10.37
MOD	MO	1	Davis Dale Conservation Area	39.0305	–92.6361	112	0.02
		7	Franklin Island Conservation Area	38.9847	–92.6959	101–229	0.01–0.18
		1	Hart Creek Conservation Area	38.7394	–92.3252	910	7.70
		1	Overton Bottoms Conservation Area	38.9234	–92.5005	864	6.60
		5	Eagle Bluffs Conservation Area	38.8383	–92.4240	720–930	4.75–9.25
		13	Boone County	38.6459	–92.2327	690–973	4.25–8.30
MS	IA	2	Port Louisa National Wildlife Refuge	41.2139	–91.1290	667–869	3.33–7.10
		4	Dead Slough	41.1018	–91.0562	695–952	3.80–8.35
	MO	3	Ted Shanks Conservation Area	39.5339	–91.1357	374–444	0.70–1.30
		1	Gilead Slough	39.1373	–90.6852	424	0.89

^a MOU = Upstream Missouri River, MOD = Downstream Missouri River, MS = Mississippi River.

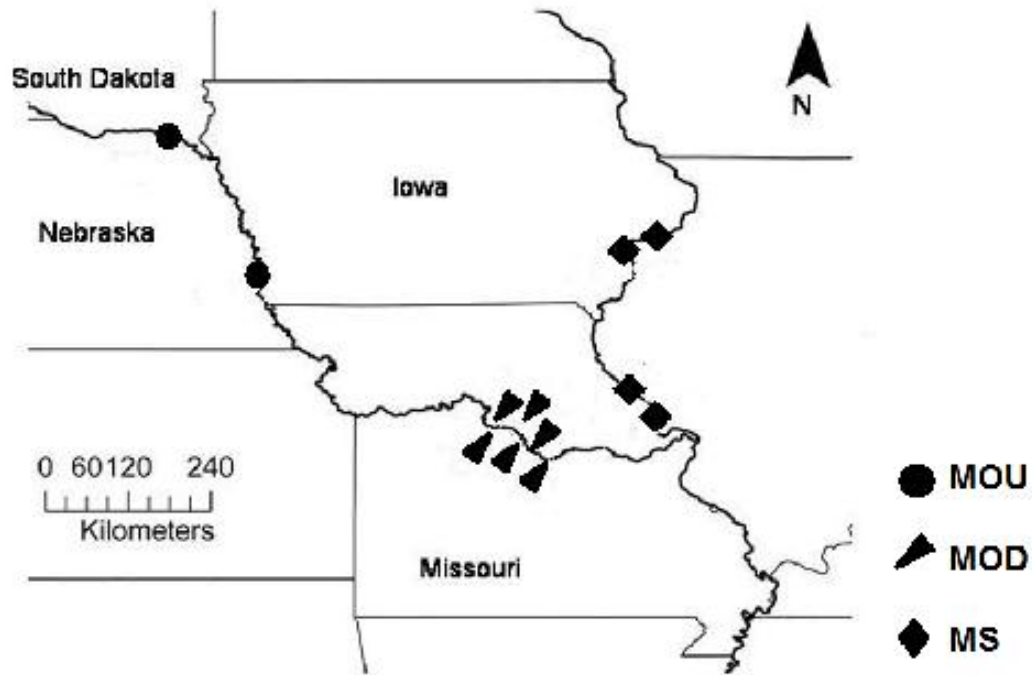

Figure 1. Sample sites from which grass carp (*Ctenopharyngodon idella*) were collected in 2008–2009 and their respective river reach groupings defined as Upstream Missouri River (MOU), Downstream Missouri River (MOD), Mississippi River (MS).

METHODS

Fish Collection

We collected samples primarily using boat electrofishing, but a small number of samples also were collected using archery or nets. We measured total length (mm) and weight (g) for each fish (Table 1).

DNA Extraction and Purification from Fish Tissues

We removed and subsequently stored fins from frozen whole fish in ethanol (Crawford et al. 2007). A sequence of extraction techniques indicated that spin column extraction kits (DNeasy; Qiagen, Inc.) yielded the greatest concentrations of pure grass carp DNA. To facilitate matriculation of fin tissues, we lysed 20 mg of fin tissue by incubating on a rocking platform at 56° C overnight in lysis buffer (ATL) and proteinase K. Once tissues were fully matriculated, we followed the spin-column protocol without modification. We initially quantified DNA yield on a Nanodrop ND-1000 spectrophotometer (Thermo Fisher Scientific, Waltham, MA, USA); concentration was standardized and visually inspected on 3% agarose gels prior to amplification.

Amplification and Analysis

Microsatellite markers were developed for 24 grass carp collected from a single location within their native range of Asia (Li et al. 2007). However, applying these markers to fish collected in the USA increased the probability of amplification failure due to potential genetic differences between the native population and our samples. To verify that amplification failures were the result of genetic variation in the sample DNA, and not to technical error, we used fin clips taken from grass carp in the Yangtze River, China as a positive control. We confirmed all amplification failures considered for quantification over multiple trials in which presence of DNA and success of primer amplification in samples from the native range were verified within a single PCR application.

We used fluorescent labels (Applied Biosystems, Inc., Foster City, CA, USA) for fragment analysis. We performed PCR amplifications in 20 μ L reaction solutions containing: 1 \times PCR buffer, 1.5 mM MgCl₂, 0.2 μ M of each primer, 200 μ M dNTPs, 1U of Taq polymerase, and 50 ng of genomic DNA. Initial PCR conditions for all primer sets were as follows: 1) initial denaturation for 4 minutes at 94° C, 2) 40

cycles of the following program: 1 minute denaturation at 94° C, 1 minute of annealing at 55° C, 1 minute of elongation at 72° C; and 3) a final elongation cycle for 5 minutes at 72° C. We diluted final PCR products 1:20 with sterile water for fragment analyses. We performed fragment size analysis using an ABI 3130XL (Applied Biosystems, Inc., Foster City, CA, USA) genetic analyzer with a 600 LIZ fluorescent-labeled size standard (Applied Biosystems, Inc., Foster City, CA, USA). We then scored output using GeneMapper v3.7 software (Applied Biosystems, Inc., Foster City, CA, USA).

Data Analysis

We quantified the number of alleles at each of 17 microsatellite loci and then compared measured allele lengths to the lengths reported in the literature along with expected and observed heterozygosity for each locus (Table 2). We calculated expected and observed heterozygosity (H_E and H_O , respectively) with significance for each microsatellite locus using GenAlEx (Peakall and Smouse 2006, Pérez-Figueroa et al. 2009). We performed phylogenetic clustering based on a measure of genetic distance that compares the number of repeats at each locus (D_{μ}) and the Unweighted Pair Group Method with Arithmetic Mean (UPGMA) with 999,999 bootstrapping (resampled with replacement) replications in POPTREE (Takezaki et al. 2010). Allele frequencies in POPTREE are based on the number of chromosomes rather than the number of individuals sampled and the specific ploidy of our samples was not known. Multiple stocking and escapement events of both triploid and diploid grass carp have been documented (Mitchell and Kelly 2006) and any selection of types could have been represented within our sample set; our objective was only to verify the usefulness of the microsatellites for use in USA populations and to provide insight into the genetic mixing of the population so we assumed that our grass carp were diploid for this analysis (i.e., 48 chromosomes per individual collected). We calculated D_{μ} among all four river groupings, including fish from China.

We evaluated genetic structure with allelic diversity (A_{ST}) using bootstrapping confidence intervals ($\alpha = 0.05$) for means of each of the 17 loci in METAPOPOP v. 2.0.a1 (Pérez-Figueroa et al. 2009). We evaluated allele frequencies to detect population bottlenecks among sample sites in the USA and China using BOTTLENECK (Cornuet and Luikart 1996, Piry et al. 1999). We tested departures from mutation drift equilibrium under HWE with 9,999 replications of the two-phase model and then tested the hypothesis with a Wilcoxon Sign-Rank two-tailed probability test at the $\alpha = 0.05$ level. We followed the recommendations of Piry et al. (1999) and applied the two-phase model, which was most appropriate for microsatellite data on 10–20 loci and at least 30 individuals.

RESULTS

We collected 56 fish throughout the Missouri and Mississippi River basins (Table 1). Amplification of all microsatellite markers was successful on USA samples with the exception of marker Ci04. All fish collected from the Missouri and Mississippi River basins for this study failed to amplify at this locus; however, the six samples from the Yangtze River, China amplified successfully. Allele size ranges between the published data and the United States samples were comparable, but a greater range in allele location distances was present in the USA fish. However, within the USA fish, fewer alleles were found at 11 of the 17 microsatellite loci evaluated. Additionally, both expected and observed heterozygosity was lower at 14 of the 16 loci (Table 2).

The phylogenetic tree of fish collected from the three Missouri and Mississippi River basins and the Yangtze River fish distinguished two population groups (Fig. 2) and the bootstrap value for the branches was 64. Both reaches of the Missouri River grouped together but fish collected from the Mississippi River were more similar to fish collected from the Yangtze River than they were to fish collected from the upstream and downstream reaches of the Missouri River.

Throughout the Missouri and Mississippi River basins, average allelic diversity was low ($A_{ST} = 0.29$; 95% confidence interval ranged from 0.08 to 0.49), whereas within population allelic diversity (A_S) was highest in the upstream reach of the Missouri River (2.27), and at least 30% less in the downstream reach of the Missouri River and the Mississippi River (1.56 and 1.39, respectively). Calculations of number of heterozygotes relative to sample size was equivalent for each of the river reaches; indicating that significant differences in levels of inbreeding are not occurring between any of the introduced population groups.

We detected no significant bottleneck between fish collected from the native and introduced populations, but there was a significant bottleneck among the basins, affecting fish collected in the upper Missouri River ($P = 0.04$).

DISCUSSION

Our results suggest that only slight genetic divergence has occurred since the USA introduction of grass carp in 1963, but little evidence exists to support division of the introduced fish into subpopulations within the Missouri and Mississippi River basins. The amplification failure of microsatellite Ci04 in the USA grass carp population, suggests that grass carp in the USA may have diverged slightly from those in China. Li et al. (2007) indicated that the 24 individuals used for primer development were unrelated, but to confirm divergence of the USA population from the native population at this locus, the marker would need to be applied to samples collected throughout the

native range and primers would need to be modified to expand the targeted region of the DNA. Expected (probability an individual is a heterozygote) and observed (actual) heterozygosity was lower in the introduced populations possibly indicating a higher degree of inbreeding than fish that were sampled by Li et al. (2007). Within the Missouri and Mississippi River populations the observed heterozygosity was lower than expected at 15 of the 16 amplifiable loci and no heterozygosity was present at

three of those loci, which also suggested some inbreeding within the introduced fish. Lack of observed heterozygosity at these three loci combined with low statistical significance between expected and observed heterozygosity ($P \leq 0.001$) for all samples tested may also indicate that the markers were not co-dominant for the USA population and were therefore unable to differentiate between heterozygotes and homozygotes for the target allele.

Table 2. Number of alleles, size range, and expected (H_E) and observed (H_O) heterozygosity for grass carp (*Ctenopharyngodon idella*) collected from each of 13 sample sites throughout the Mississippi and Missouri River basins, USA, 2008–2009.

Locus	Published ($n = 24$)				Detected ($n = 56$)				ChiSq ^a	df ^b
	No. alleles	Size range (bp)	H_E	H_O	No. alleles	Size range (bp)	H_E	H_O		
Ci01	7	107–123	0.78	0.71	5	125–149	0.61	0.78	30.25	10
Ci02	13	123–149	0.87	0.83	2	12–204	0.52	0.0	26.00	3
Ci03	7	107–123	0.75	0.59	5	120–142	0.43	0.0	152.00	10
Ci04	12	172–202	0.88	0.79	0					
Ci05	8	115–131	0.81	0.67	2	120–129	0.04	0.0	51.00	1
Ci06	8	163–195	0.84	0.75	6	106–197	0.79	0.22	79.53	15
Ci07	4	111–117	0.76	0.63	4	119–181	0.48	0.3	36.11	6
Ci08	11	171–191	0.8	0.75	4	181–198	0.65	0.61	48.15	6
Ci09	7	117–139	0.83	0.79	5	119–198	0.28	0.21	87.30	15
Ci10	11	188–214	0.74	0.75	7	124–226	0.57	0.68	140.00	21
Ci11	4	104–124	0.77	0.67	6	124–218	0.68	0.57	69.72	15
Ci12	11	180–212	0.85	0.88	7	125–225	0.7	0.24	133.56	21
Ci13	4	209–215	0.76	0.75	5	125–225	0.21	0.07	150.08	10
Ci14	4	122–128	0.70	0.46	7	121–225	0.64	0.47	130.65	21
Ci15	8	188–208	0.85	0.75	6	131–224	0.65	0.26	42.95	10
Ci16	4	103–111	0.73	0.71	8	121–24	0.59	0.53	122.41	21
Ci17	4	162–182	0.59	0.59	7	72–204	0.57	0.69	166.14	21

^a Chi-square test values of differences of observed versus expected values from published data by Li et al. (2007). $P \leq 0.001$ for all markers tested; ^b degrees of freedom; Blank cells indicate no data.

Furthermore, the bottleneck identified between the Missouri River Upstream sample group and the other sample groups suggested that some divergence and isolation may be occurring within the USA. However, all other analyses suggested that this differentiation remains minor at the present time and that considerable mixing is still occurring. Phylogenetic clustering indicated weak separation between the population in the Mississippi River and the populations in the up- and downstream reaches of the Missouri River. It is possible that the fish in the Mississippi River are most similar to fish in the Yangtze River because the first escapees into the wild spread from tributaries in the Mississippi River basin prior to entering

the Missouri River basin. However, it is also possible that multiple introductions with varying source populations (e.g., Malaysia and Taiwan) may have provided the initial genetic variability within the basin, the last reported introductions from outside the USA were in 1964 (Mitchell and Kelly 2006). Private individuals and public agencies alike have stocked grass carp throughout the United States, and escapes have occurred from any number of these stockings, providing possible sources for genetic variation (Nico et al. 2011). Among group F_{IS} and F_{IT} values were slightly negative, which is indicative of outbreeding (Wright 1969). Overall, the USA grass carp population appears to be genetically mixed and at an early point in invasion history

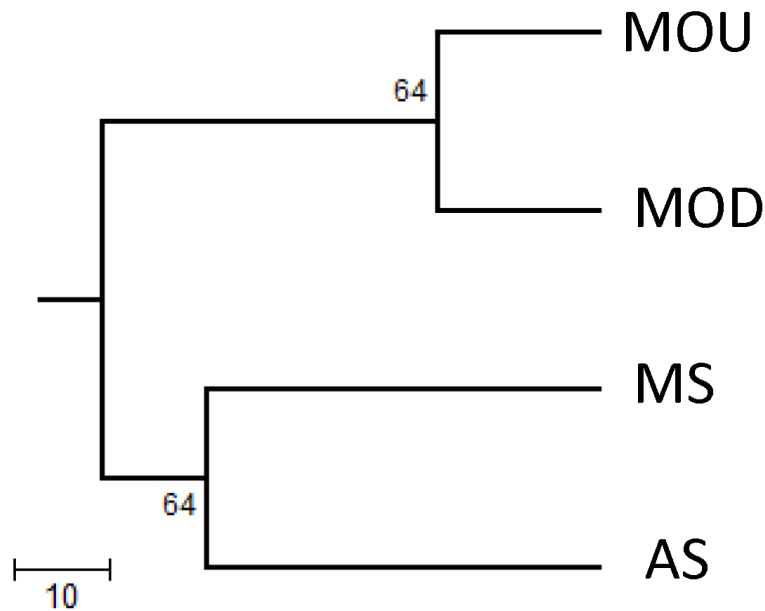

Figure 2. Unweighted pair group method with arithmetic mean cluster diagram of bootstrapped genetic distances (D_{μ}) among grass carp (*Ctenopharyngodon idella*) samples from Upstream Missouri River (MOU), Downstream Missouri River (MOD), Mississippi River (MS), and Yangtze River, Asia (AS). The sum of the branch lengths from the taxa to the node connecting the two taxa is half the distance between the two taxa, and the number on each branch is the proportion of the total bootstrapping replications in which that branch grouping occurred.

Our analysis did not indicate a bottleneck between our samples from China and the USA groups, which may be a result of limited genetic information for the Asian samples. Interestingly, there is a bottleneck between fish of the Upper Missouri River (South Dakota and Nebraska) and all other sampled fish (Lower Missouri River, Upper Mississippi River, and China). This deviation from mutation drift equilibrium among the introduced populations likely results from a reduction in the number of discovered alleles relative to sample size in the upper Missouri versus the lower

Missouri River reach (4.70 and 8.98 alleles, respectively). This may suggest that sufficient allelic diversity from the native range was represented during initial introduction, but subsequent upstream range expansion in the Missouri River has resulted in limited genetic diversity at the leading edge of the range. Alternatively, fish from the Nebraska reach of the Missouri River may be triploid, which would skew our estimation of genetic distance based on diploid individuals with 48 chromosomes. Within our study area, only Iowa, Kansas, and Missouri allow fertile (e.g., diploid) grass carp

to be released into the wild (Mitchell and Kelly 2006), but fishes migrate throughout connected waterways without respect for political boundaries and both diploid and triploid fish may be present at any location within the range.

This study indicated some support for two population groups (Mississippi River versus Upper and Lower Missouri River); however support for division into two groups was weak. Lack of distinct subpopulations of grass carp in our study corroborates studies of diversity in closely related bighead (*Hypophthalmichthys nobilis*) and silver carp (*H. molitrix*). Factors that appear to influence grass carp population structure also were cited as influential factors in bighead and silver carp genetic structure: rapidly expanding population (Mitchell and Kelly 2006), recurrent adaptation to a novel environment (Cox 2004), and multiple independent introductions (Kolar et al. 2007). Diversity of Asian carp in the USA seems to be the result of a mixture of drivers from the native range (e.g., founder effect) and the introduced range (e.g., multiple introductions).

MANAGEMENT IMPLICATIONS

Continued research on genetics of grass carp and their ecology in Great Plains streams will contribute to conservation of these fish in the native (acceptable) range and mitigation of the deleterious effects in the invaded range. One example of how genetic analyses might be used to develop management strategies includes identifying subpopulations as sources or sinks for the grass carp metapopulation in the USA. When two subpopulations mix, they share a common gene pool. Thus, the subpopulation that is most similar genetically to other subpopulations is likely the one that interbreeds most frequently (e.g., a source). These subpopulations could be targets for removal efforts or other eradication measures. Further studies that incorporate samples from the initial escapement areas (Mississippi River, Arkansas) and a comprehensive characterization of fish in the native ranges would be informative to evaluate the effect of translocation into the United States.

ACKNOWLEDGMENTS

We thank our many collaborators that provided grass carp samples for this project: D. Chapman, J. Tong, S. Stukel, K. Buhl, K. Steffensen, B. Eder, M. Hamel, B. Schonhoff, K. Stauffer, V. Sterner, D. Bierman, K. Hansen, and S. Gritters. We are very appreciative of the guidance and assistance provided by Dr. K. Gedye in the Functional Genomics Core Facility at South Dakota State University (SDSU) and K. Christensen in the School of Molecular Biosciences at Washington State University. This project was funded by an In-House Grant to K. Bertrand, M. Brown, and D. Auger from the SDSU College of Agriculture and Biological Sciences, and by a Joseph F. Nelson Undergraduate Mentorship to B. Adams. We also

thank J. Lamer and two anonymous reviewers for their comments on an earlier draft of this manuscript.

LITERATURE CITED

- Bailey, W. M. 1972. Arkansas' evaluation of the desirability of introducing the white amur (*Ctenopharyngodon idella* Val.) for control of aquatic weeds. Little Rock, Arkansas: Arkansas Game and Fish Commission. Mimeographic Reproduction.
- Cornuet, J. M., and G. Luikart. 1996. Description and power analysis of two tests for detecting recent population bottlenecks from allele frequency data. *Genetics* 144:2001–2014.
- Courtenay, W. R., Jr., D. A. Hensley, J. N. Taylor, and J. A. McCann. 1984. Distribution of exotic fishes in the continental united states. Pages 41–78 in W. R. Courtenay, Jr., and J. R. Stauffer, Jr., editors. *Distribution, biology and management of exotic fishes*. Johns Hopkins University Press, Baltimore, Maryland, USA.
- Cox, G. W. 2004. *Alien species and evolution: the evolutionary ecology of exotic plants, animals, microbes, and interacting native species*. Island Press. Washington, D.C., USA
- Crawford, B., T. Mosey, and D. Johnson. 2007. Carcass counts. Pages 59–86 in D. H. Johnson, B. M. Shrier, J. S. O'neal, J. A. Knutzen, X. Augerot, T. A. O'neil, and T. N. Pearsons, editors. *Salmonid field protocols handbook: techniques for assessing status and trends in salmon and trout populations*. American Fisheries Society, Bethesda, Maryland, USA.
- Hutorowicz, A., and J. Dziedzic. 2008. Long-term changes in macrophyte vegetation after reduction of fish stock in a shallow lake. *Aquatic Botany* 88:265–272.
- Jenkins, J. A., and R. G. Thomas. 2007. Use of eyeballs for establishing ploidy of asian carp. *North American Journal of Fisheries Management* 27:1195–1202.
- Kolar, C. S., D. C. Chapman, W. R. Courtenay, C. M. Housel, J. D. Williams, and D. P. Jennings. 2007. *Bigheaded carps: a biological synopsis and environmental risk assessment*. American Fisheries Society, Special Publication 33. Bethesda, Maryland, USA
- Li, J. L., Z. Zhu, G. Wang, Z. Bai, and G. Yue. 2007. Isolation and characterization of 17 polymorphic microsatellites in grass carp. *Molecular Ecology Notes* 7:1114–1116.
- Mitchell, A. J., and A. M. Kelly. 2006. The public sector role in the establishment of grass carp in the United States. *Fisheries* 31:113–121.
- Nico, L. G., P. L. Fuller, and P. J. Schofield. 2011. *Ctenopharyngodon idella*. USGS nonindigenous

- aquatic species database, Gainesville, Florida, USA. <http://nas.er.usgs.gov/queries/factsheet.aspx?Speciesid=514> revision date: 2/5/2010.
- Peakall, R., and P. E. Smouse. 2006. Genalex 6: Genetic analysis in excel. Population genetic software for teaching and research. *Molecular Ecology Notes* 6:288–295.
- Pérez-Figueroa, A., M. Saura, J. Fernández, M. Toro, and A. Caballero. 2009. Metapop—a software for the management and analysis of subdivided populations in conservation programs. *Conservation Genetics* 10:1097–1099.
- Pipalova, I. 2003. Grass carp (*Ctenopharyngodon idella*) grazing on duckweed (*Spirodela polyrhiza*). *Aquaculture International* 11:325–336.
- Pipalova, I. 2006. A review of grass carp use for aquatic weed control and its impact on water bodies. *Journal of Aquatic Plant Management* 44:1–12.
- Piry, S., G. Luikart, and J. M. Cornuet. 1999. Bottleneck: a computer program for detecting recent reductions in the effective population size using allele frequency data. *Journal of Heredity* 90:502–503.
- Ricciardi, A., and J. B. Rasmussen. 1998. Predicting the identity and impact of future biological invaders: a priority for aquatic resource management. *Canadian Journal of Fisheries and Aquatic Sciences* 55:1759–1765.
- Shireman, J. V., and C. R. Smith. 1983. Synopsis of biological data on the grass carp, *Ctenopharyngodon idella* (Cuvier and Valenciennes, 1844). Food and Agriculture Organization Fisheries Synopsis 135.
- Stevenson, J. H. 1965. Observations on grass carp in arkansas. *The Progressive Fish-Culturist* 27:203–206.
- Takezaki, N., M. Nei, and K. Tamura. 2010. Poptree2: Software for constructing population trees from allele frequency data and computing other population statistics with windows interface. *Molecular Biology and Evolution* 27:747–752.
- Wright, S. 1969. The theory of gene frequencies, volume 2. University of Chicago Press. Chicago, Illinois, USA.

Submitted 4 March 2011. Accepted 6 December 2011.
Associate Editor was Brian G. Blackwell.